



GuidEx

Technicians Installation guide

Contents

Part 1: QA'ing the Kit.....	3
Overview.....	3
Stocktake of supplied parts	3
Testing the kit.....	3
Part 2: Installing the Kit.....	3
Overview.....	3
Machine Inspection.....	3
Identifying Install/Mounting Locations.....	4
Tablet.....	4
Receiver.....	4
Antennas.....	4
Harnesses and Cabling.....	5
Power Connections.....	5
Part 3: Machine Measure Up.....	5
Overview.....	5
Creating The GuidEx Config XML File.....	6
Machine/Geometry.....	7
Configuring Machine Parameters	7
Machine/General Settings	9
Machine/Inertial Measuring Unit Settings.....	10
Configuring GNSS Correction Source Parameters	10
Correction Source and Precision Thresholds	10
Configuring Target Parameters.....	11
Configuring Messaging Parameters.....	13
Configuring Cloud Setup Parameters	14
Configuring Pad DB Parameters.....	15
Copying The Machine XML File To USB.....	16
Part 4: Commissioning the Installation.....	16
Overview.....	16
Quick Check.....	16
Positioning Check.....	17
First Check.....	17
Second Check	17
Final Check	17

Adjustments	18
Reassemble Machine	18

Please read this guide in full prior to beginning your GuidEx installation

Part 1: QA'ing the Kit

Overview

Part 1 describes the steps taken by SITECH/UPG during the GuidEx QA process.

Stocktake of supplied parts

The GuidEx kit should contain the following parts:

- 1 x Trimble Receiver
- 1 x TD540 Tablet
- 1-2 x Zephyr Rugged 3 GNSS Antennas
- 1-2 x TNC-TNC Coaxial Antenna Cables
- 1 x Display Harness
- 1 x Main Harness
- 1 x Power Harness
- 1 x Tablet Mounting Solution

Testing the kit

All components are to be connected using the relative cabling and the GuidEx application loaded onto the tablet. Run GuidEx, load a project and machine file and confirm a location that corresponds with the actual location of the primary GNSS antenna (when checking the receiver Web UI), and the grid position as calculated in the GuidEx application (when checking the PRP)

Part 2: Installing the Kit

Overview

Part 2 describes the fundamentals required to complete the installation of GuidEx on most HME equipment. It is expected that the technician(s) will:

- Be trained and competent
- Have auto electrical knowledge
- Be familiar with the operation of the GuidEx solution and its components
- Preferably have knowledge of geospatial fundamentals

Machine Inspection

Prior to carrying out any work on the machine, it is recommended that you first inspect it for

damage – particularly around areas where you'll be gaining access for the installation such as dash panels, wiring harness/connectors, 3rd party componentry etc.

All damage – no matter how minor – should be photographed and your site contact notified prior to commencing work. It is also worth noting the original position of items such as reverse camera monitors, toggle switches, mirrors, etc., should these need to be moved during installation. If, after removing dash panels, etc., there are noticeable issues with existing wiring/componentry, this should be photographed, and your site contact notified.

Identifying Install/Mounting Locations

Tablet

The TD540 tablet weighs approx. 2.1 kg and consideration for this must be made when deciding on an appropriate mounting location. Usually, there will be suitable captive nuts on the ROPS frame that can be utilised, sometimes with the manipulation of existing components mounted in the cab such as Loadrite or Reversing Camera Monitors. A bracket may need to be fabricated to utilise a captive nut/fastening solution in a nearby location to where the tablet will sit.

If no real estate is available off the ROPS frame or other suitable structure, then it is recommended to use the Trimble Mag Mount (PN# 110262-00).

- **Mounting to plastic surfaces is not recommended.**
- **Always consult the customer to confirm their preferred location for mounting the TD540 tablet.**
- **Consider the impact of glare from reflections off the glass or indicator/warning lights when identifying a suitable mounting location.**

Receiver

It is important to mount the receiver to a firm surface as significant vibration can affect the IMU operation. Additionally, when mounting the receiver, it is important to observe the orientations supported by GuidEx. There are 16 available orientations about the receivers X, Y, and Z axis that are supported.

- **IMU operation can be affected if the receiver is mounted with the "X" axis running vertically. The 8 orientations possible in this position are not supported.**

Antennas

Trimble recommend a minimum spacing of 1.2 meters between the GNSS antennas, with the primary antenna being the positioned to the left of the centerline of the machine in direction of travel. Additionally, when mounting both GNSS and LTE/Wi-Fi antennas, consideration must be made to ensure that they are mounted in a location where:

- Height limitations on site or daily operation of the asset won't result in damage to either antenna
- The GNSS antennas will have as much line of sight to the sky as possible. The GNSS antenna must be externally mounted and clear of metallic interference.
- The LTE/Wi-Fi antennas won't flex and foul on any handrails or other structure. While

considering height restrictions, the top of a handrail is usually the best place to mount a Hi Gain antenna.

- **Always advise the customer of the recommended location for mounting the antennas.**

Harnesses and Cabling

“Best practice” should be employed when running harnesses and other cables. Examples of best practice are:

- Avoid pinch points
- Avoid sharp edges
- Provide enough slack when running along a moving part to mitigate any tension caused by said moving part
- Avoid excessive bends when running antenna cables. Typically, the bend radius should not be tighter than 10% of the diameter of the cable.

Power Connections

GuidEx requires minimal connectivity to the asset – 8-32VDC constant (or ignition) and ground. Connection to constant is preferred, but ignition can be used if the customer prefers and on the switched side of the cabin isolation switch, if fitted. It is recommended that a wiring diagram for the asset being installed into is consulted for the best power locations. If one is not available, it is recommended that Constant (or Ignition) feeds are picked up off the back of the fuse panel. Fuse piggyback connections and scotch locks are not to be used, and crimping is preferred over solder – the latter not being allowed at some sites. A multimeter should be used to confirm correct connections, and the supplied fuses must be used when making a connection.

Part 3: Machine Measure Up

Overview

Part 3 describes the measure up required following the installation of the GuidEx hardware. It is necessary to measure up the key components and enter the values into GuidEx Manager or an alternative in-house software solution for creation of a Machine XML file. This file contains the information that the GuidEx App requires to record the various data for a project.

Machine XML files are typically unique to each machine, but if one or more machines have components installed in the same locations, then a template can be created using the same measurements, with only the machine name requiring a change.

Creating The GuidEx Config XML File

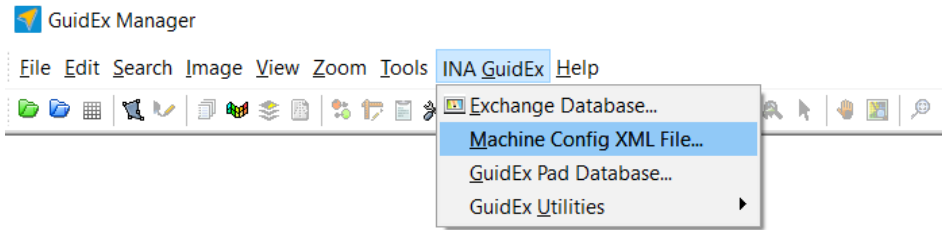





This utility is accessed from the “Machine Config XML File...” menu item in the “INA GuidEx” menu of GuidEx Manager.

In addition to the exchange database and the Task/Pad database, the Configuration XML File is one of three principal sets of operating parameters. These parameters include the following:

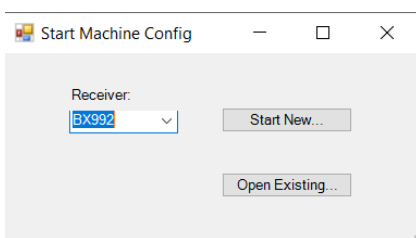
1. Machine name, antenna height and machine geometry (length, width, and placement of GNSS antenna, IMU & position reference point)
2. Inertial Measuring Unit (IMU) orientation, and pitch and roll thresholds
3. GNSS correction source and precision thresholds
4. Target navigation parameters.
5. Messaging parameters - NMEA, PPS & Record Trigger
6. GuidEx Connect cloud setup parameters.
7. Standby behaviour (whether to prompt operator and time between prompts)

When launched, you will first be prompted to define which hardware platform you are using this XML file on (current BX992 or legacy NAV900). Here you can either start a new file or open an existing file to edit.



Once defined, you can still open an existing XML by pressing . Once file is complete, press  to save it. For a new XML file, complete all sections and press .

The file must have the name 'Config_MyMachine.xml' where 'MyMachine' is the name you entered for the machine.

The Configuration File utility has six basic sections, each on its own tab page: Machine, GNSS Correction Source, Target, Messaging, Cloud Setup, Pad DB.

Machine/Geometry

Configuring Machine Parameters

Machine Geometry

Start by defining your machine geometry. Press the Machine Geometry button and a dialog will display where you can interactively define the machine type, Position Reference Point (PRP), antenna location(s), inertial measuring unit (IMU) location, and four points that roughly describe your vehicle shape.

Once the Position Reference dialog is displayed, select a tab page that depicts your machine type. Then press the 'Load This Vehicle in Designer' button at the top of the tab page. This will display the vehicle in the Designer:

The screenshot displays the 'Machine Geometry' configuration interface. On the left, the 'Geometry Controls' panel includes options for Position Reference Point (PRP), GNSS Antenna, IMU, and Dual Antenna, along with directional buttons (L, U, R, D). Below these are input fields for the 'Relation of PRP To Items (m)', such as Antenna Ahead (1.900), IMU Ahead (1.900), and four sets of Point Ahead/Across coordinates. A 'Configure For Entered Values' button is at the bottom of this panel. The central 'Designer' window shows a 3D model of a machine with a green bounding box and the text 'Width: 7.450 m Length: 11.400 m'. Below the model are PRP (from rear left) settings: PRP Ahead (5.700), PRP Across (3.725), PRP Up (0.000), and an 'Apply' button. The right panel features a tabbed interface with 'Utility', 'Vibe', 'Large Dozer', 'Small Drill', 'Grader', and 'Small E' tabs. A 'Dimensions' dialog is open, showing 'Default' selected with 'W:7.450m L:11.400m', and 'Custom' options for Width (5) and Length (9). A '<< Load This Machine In Designer' button is located at the bottom of this panel.

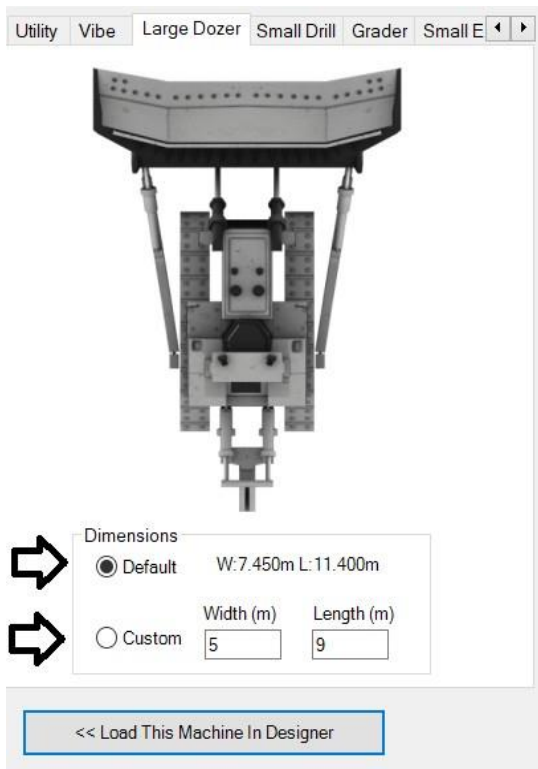

Note that each machine has its own predefined width and height. When a machine is loaded into the Designer, these will appear at the bottom of the Designer vehicle depiction. If your machine does not match these default dimensions, you can override them by entering the actual dimensions in the top toolbar and checking the radio button next to Custom, and then loading the machine in designer.

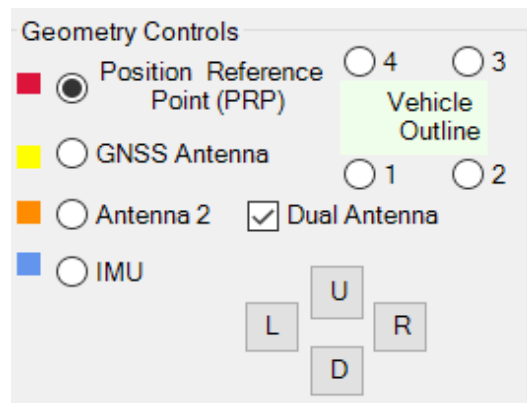

There will be 4-5 settings to define, depending on if you are running single or dual antenna. The red circle is the Position Reference Point (PRP). This is the position that will be the primary position for navigation and is the recorded point in the GuidEx log file. This position is a virtual lever arm offset, leveraging the IMU heading, pitch, roll to calculate the virtual point. The yellow point is the location of the primary GNSS antenna. The blue circle is the IMU position on the machine. The orange circle is the secondary antenna (optional), which displays when the 'Dual Antenna' box is enabled. The four green points are used for the machine footprint to determine the machine position in reference to exclusion/ inclusion zones.

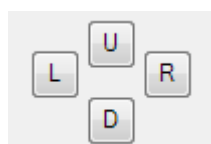

To move the machine footprint points, select the radio button by the point to be moved and press these buttons. U = Up, D = Down, L = Left and R = Right.

Relation of PRP To Items (m)

Antenna Ahead	1.900
Antenna Across	0.000
Antenna Height	0.000
IMU Ahead	1.900
IMU Across	0.000
IMU Up	0.000
Point 1 Ahead	-5.700
Point 1 Across	-3.725
Point 2 Ahead	-5.700
Point 2 Across	3.725
Point 3 Ahead	5.700
Point 3 Across	3.725
Point 4 Ahead	5.700
Point 4 Across	-3.725
Primary GNSS to Secondary GNSS	
Antenna2 Ahead	0.000
Antenna2 Across	0.750
Antenna2 Up	0.000

Configure For Entered Values

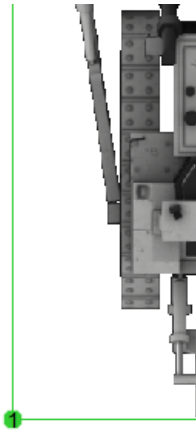

Width: 7.450 m Length: 11.400 m

PRP (from rear left)

PRP Ahead	5.700
PRP Across	3.725
PRP Up	0.000

Apply

If you want to enter explicit values into the text boxes, do so then press the Configure for Entered Values button. Note that all values are in meters and are the distances ahead or across from the PRP.

Once you have defined the machine geometry, press the  button to return to the main configuration dialog:

Machine/General Settings

General Inertial Measuring Unit

Machine Name	MyVehicle
Fleet Name	
Receiver Model:	BX992
Antenna Model:	Zephyr 3 Rugged

Now give your machine a name. This name is displayed on the tablet logged in the GuidEx log file. Fleet name is optional.

Max

Volume = 5

Min

allow override

Select a sound volume value and if you want to give the user the option of overriding the volume set, the check the 'allow override' check box. If allow override is unchecked, if the operator attempts to change the volume via the tablet settings, this will be overridden by GuidEx back to the level defined here.

Time zone

US/Mountain

Optionally, you can define a time zone to set the tablets clock to

Machine/Inertial Measuring Unit Settings

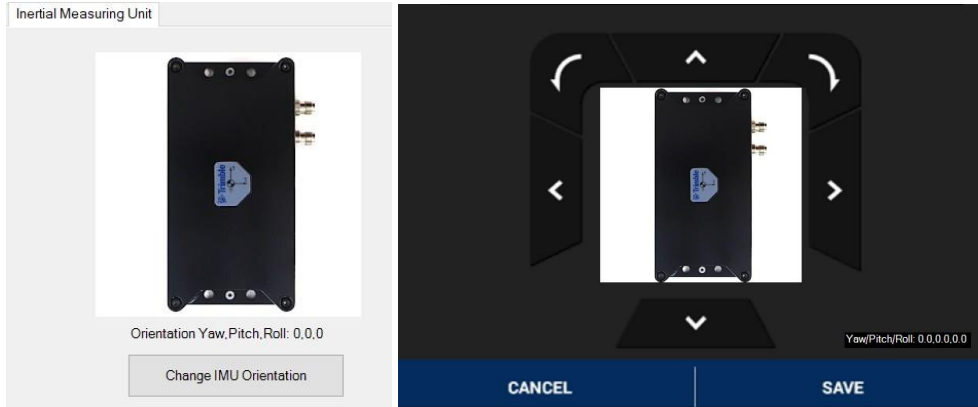

IMU Orientation – Assuming the top of the screen is the front of the machine, select the IMU orientation that best describes your installation. Click "Change IMU Orientation" to rotate the IMU graphically.

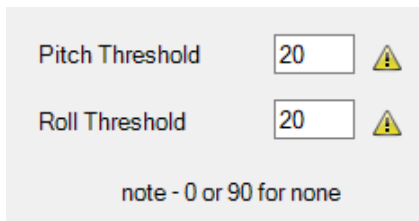

Pitch and roll values are in degrees that indicate the maximum angle before alarms sound.

Configuring GNSS Correction Source Parameters

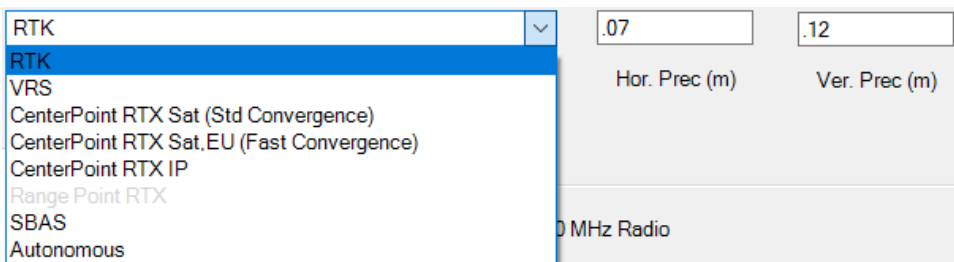

Correction Source and Precision Thresholds

The user should select a correction source. You will have one or several other controls to configure depending on the correction source. Note that every time you select a different source, the suggested precision thresholds will be selected for you, but you may enter any values you consider appropriate for your operations. Below are the settings that should be addressed for each correction source:

Autonomous – There are no settings associated with Autonomous.

SBAS – The satellite-based augmentation systems (SBAS) with free correction services are: WAAS (Wide Area Augmentation System) in North America

EGNOS (European Geostationary Navigation Overlay Service) in Europe MSAS (Multi-functional Satellite Augmentation System) in Asia Pacific regions Typically, you will set this to 'Automatically Selected from User Position'.

RTX Satellite – These services are optional and requires an unlock. The RangePoint service has an accuracy < 6" (15 cm) while the CenterPoint service is < 1.5" (3.8 cm).

You must select one of five existing regional services or a custom service (in which case frequency and baud rate entries are required).

*Note: RangePoint RTX is only available for use on legacy NAV900 platform, which is why it is disabled in the screenshot above (configuring for BX992 platform).

CenterPoint RTX IP (Modem) – CenterPoint RTX IP is a cellular broadcast subscription service for corrections with < 1.5" (3.8 cm) accuracy. A connected wireless modem receives these signals.

There is a fast restart option only.

CenterPoint VRS – This service is optional and requires an unlock. CenterPoint VRS is a cellular-broadcast RTK correction service from a ground-based reference station using a modem and requires a connected wireless modem.

Options include username, password, host, port, mount point, xFill (and related frequency options).

RTK – RTK is a radio-broadcast correction service originating from a ground-based reference station and received by radio signal. The AG-815 is an integrated radio capable of receiving these signals.

Options include whether you are using 450 MHz or 900 MHz radios. If using 450 MHz, then the specific 450 MHz frequency is required along with mode protocol). If using xFill, related frequency options are required.

Configuring Target Parameters

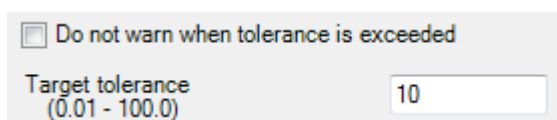

Do not warn when tolerance is exceeded

Target tolerance (0.01 - 100.0)

This number will draw a circle around the target with the specified radius. Recording is enabled when the vehicle enters this circle, or the vehicle stops. The 'Do not warn when target tolerance is exceeded' checkbox is an off or on option. When off, if the user records the point outside the target tolerance above, the user is warned. If on, this warning is not issued.

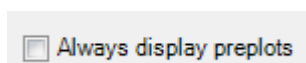

Always display preplots

This is an off or on setting. If off, after a point is shot, it disappears from the screen. If on, it remains.

Enable auto-sequence of targets

Increment (+/- 0-100000)

Use this control to change the current point increment and the direction. For example, if your stations are 1,2, 3... and you enter '+1' for the increment, once station 1 has been surveyed, station '2' is automatically targeted. If you enter '+2' then after station 1 has been surveyed, station 3 is targeted and so on. A minus value reverses that logic. For example, if you enter '-2' and you have just surveyed station 5, then the next targeted station is 3. Values can be defined as integers or decimals. Note that '0' and '-0' (without the single quotes) are special values that will simply sequence down the list and up the list respectively, no matter what the station value or text is. If the station has alpha and numeric characters, the alpha characters are ignored. For example:

- 1234test uses 1234 for increment calculation.
- test1234 uses 1234 for increment calculation.
- te123st uses 123 for increment calculation.

Sequence tolerance
(0.01 - 100)

When auto-sequence is disabled, and the machine exceeds the sequence tolerance distance from the currently recorded point (without sequencing to next point), a warning dialog appears asking the user to select the target (I.E: either use previously recorded point or sequence to next point).

 Enable auto-stop navigation on record point

This is an off or on setting. When enabled, navigation is stopped as soon as a point is recorded. You might want to use this if you do not have a viable point sequence, that is, when you record one point, neither adjacent point in the list is the next target. In this way you can manually select the next point to navigate.

 Enable delayed recordDelayed recording time (sec)
(15-300)

This is an off or on setting. Enabling this setting utilises the value specified. Setting a delay will initiate a countdown of the selected number of seconds before a point is recorded. The log dialog will display the count down and you will be able to force it to record before the countdown is over. This feature is typically used in high multipath environments to allow the GNSS receiver time to model the multipath to obtain an improved position.

 Do not warn about previously recorded points

This is an off or on setting. When enabled, the user is not alerted to the fact that a point might have been previously recorded. When disabled, the warning is issued.

Play tone on internal trigger

This is an off or on setting. When enabled, a tone is played when an external trigger is received.

Enable target information on record

This enables a dialog post point recording to allow the user to enter the comments about the point recorded.

Enable guidance inside tolerance

This is an off or on setting. When enabled, values to target center remain after you have entered the target tolerance. When disabled, the guidance indication simply states you have arrived.

Enable auto-zoom to target

This is an off or on setting. When enabled, GuidEx will automatically zoom in as you approach the target.

Always display the connector between machine and target

This is an off or on setting. When on, a connector line will always be displayed the machine and target. When off, the connector line will only be displayed when auto-zoom is enabled, and the machine is far from the target.

Enable rapid logging

By default, GuidEx records timed positions every ten seconds and 1 meter (meaning, if the new position is at least one meter from the previous log record, and 10 seconds have elapsed). With this rapid logging option checked, timed positions will be logged once per second with the same one-meter distance requirement.

Enable target recording inside tolerance boundary Duration (min):

If enabled, when a machine enters the target tolerance boundary of a point, GuidEx will log Event Type 11 records in the duration defined here. This is useful in scenarios with long occupation times on points, where operators may forget to survey a point.

Configuring Messaging Parameters

Record Trigger

On

Digital trigger voltage level:
2.0V

To generate a log record each time a voltage is detected, check the 'On' checkbox and select the polarity and voltage expected.

PPS Output

On

PPS messages can be sent from the receiver to a 3rd party device, using the PPS lead on the cable.

Configuring Cloud Setup Parameters

This section defines configuration parameters used when connecting the tablet via internet connection to the GuidEx Connect platform for file sharing and tracking.

ClientID: Password: Show

Project Name

Login parameters and project folder in which the tablet will communicate to. The ClientID and Password (Secret). These are found by logging in to GuidEx Connect, going to the profile icon (upper right corner) and clicking the "Name:" option, which displays account settings. The Project Name should match the Project folder created on the GuidEx Connect platform which the data will be sent to/from.

File Sync Interval: Minutes

File Sync Interval defines how frequently GuidEx should automatically check for new files (in the Updates folder of GuidEx Connect). Regardless of whether this section is used or not, GuidEx always checks for new files in the Updates folder of GuidEx Connect each time the GuidEx app launches on the tablet.

Export outstanding log file to cloud upon target point record

When enabled, each time a machine records a point via the right drawer target list, an outstanding records log file will be uploaded to GuidEx Connect Uploaded folder.

Auto Upload

Enable

Interval:

Outstanding records
 Today's records
 All

When enabled, the specified log file type is exported to GuidEx Connect in the specified duration. Note that this duration is app runtime.

Machine Interval

When enabled, the latest machine time event record (type 0) is sent to GuidEx Connect's track machine page based on the duration defined.

Zone Alerts

When enabled, exclusion/inclusion zone breach and proximity events are sent to GuidEx Connect's track machine page.

GNSS Precision Alert

When enabled, GNSS Precision threshold alerts are sent to GuidEx Connect's track machine page.

Target Tolerance Recording Event

When enabled, and if the Target Tolerance setting in Target Parameters tab is enabled, when a Target Tolerance recording (type II) occurs, that point will be sent to GuidEx Connect's track target page.

Target Moved Alert

When enabled, if an operator move/offsets a target point (in right drawer), that event will be sent to GuidEx Connect's track target page.

Recorded Event

When enabled, each time an operator record's a target point (from right drawer), that event will be sent to GuidEx Connect's track target page.

Configuring Pad DB Parameters

You can set the following prompt times for use with Pad DB workflows:

no prompt ▼

When the machine is in Standby or performing an active task with no pad and inside a pad, a prompt is displayed to choose a pad related task. On dismissal, this prompt is re-issued every number of minutes specified here. You can also set to 'no prompt'.

no prompt ▼

When in Standby and the machine is stationary for the number of minutes specified here, operator is prompted for a standby reason. You can also set to 'no prompt'.

never dismiss ▼

When in Standby and the machine is stationary and the prompt to choose a Standby reason is displayed, this prompt will auto-dismiss after the number of minutes specified here. You can also set to never dismiss.

0 (no) ▼

Flash screen when driving in standby. Set to Yes or No.

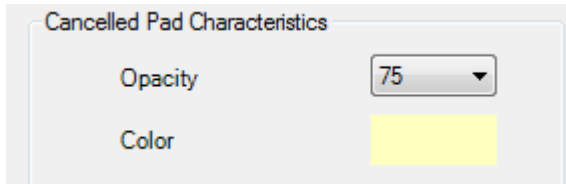

A cancelled pad will have the opacity and colour specified here.

Copying The Machine XML File To USB

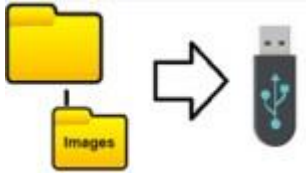

Once you have created and saved your Machine xml file, copy the automatically generated “.xml” and “.png” files to a memory stick. Plug the memory stick into the tablet and follow the procedure for importing a machine xml in the GuidEx application.

Part 4: Commissioning the Installation

Overview

Part 4 describes the requirements to confirm the accuracy of the GuidEx location calculations.

- **Prior to conducting the commission checks, ensure that the machine config xml has been loaded and “Reset Setup” has been completed. This will write the measure up values to the receiver, which should be confirmed by checking the “Receiver Configuration>INS” page in the Web UI under the GNSS and IMU lever arm sections.**

Quick Check

Once all connections have been made, it is recommended to power up the tablet and perform a “Quick Check” prior to replacing dash panels etc. This way, if any issues are found, they can be quickly remedied without obstruction.

- **You may choose to complete the following steps prior to reassembling any removed panels, but as the machine will need to be maneuvered, any loose panels, wiring and components must be secured first.**

Positioning Check

Once basic functionality is confirmed, GuidEx must be checked against a local project using the machine config xml created in Part 3. The project should have at least one exclusion/inclusion zone and a point to navigate to. Zones and points should have a physical marker, such as paint, or an object placed on the ground.

- **If a local project is unavailable, refer to the GuidEx Manager User Guide for information on how to create a project.**

Confirm the co-ordinate system used for the project and its data and setup your Rover/Controller project to match. It is highly recommended that both GuidEx and the Rover are on the same GNSS correction services.

- **Failure to do so may result in positioning discrepancies between the rover and the GuidEx system.**

First Check

Position Rover on the GuidEx PRP (Position Reference Point) and confirm eastings and northings. Confirm these values with the eastings and northings found in the “Position Widget” inside the GuidEx application.

Second Check

Navigate as close as possible to the point created in the GuidEx project using the application as the guide. Exit the machine and confirm the point is within an acceptable tolerance, which will be determined by the accuracy code applied to the receiver module. Repeat this step again, but approaching the point from a different direction.

- **Navigating along cardinal points will make it easier to determine any easting and northing discrepancies.**

Final Check

If possible, maneuver the machine in/out of the zone created in the project and confirm that the appropriate alarms are sounding.

Adjustments

If there are discrepancies in the positions between GuidEx and Rover, it may be necessary to review the machine measure up, but first confirm that measure up values of the GNSS and IMU components have been written to the receiver. If these are correct, double check the measurements and amend the machine config file if need-be.

Some common reasons for position discrepancies are:

- Incorrect/dissimilar co-ordinate systems between GuidEx and Rover
- Incorrect/dissimilar GNSS correction services
- Incorrect measure up
- Primary and Secondary antennas are reversed

Reassemble Machine

Replace all panels and 3rd party components and confirm correct operation of the machine prior to handing over to the customer. It may be necessary to engage the customer to review the machine to assist with this, as they will be familiar with its operation.

- **Failure to fully commission the system will have the job considered incomplete unless prior clearance has been given for exceptional circumstances (I.E the asset is unable to be powered up due to maintenance work)**
- **Commissioning must be performed with a rover by a trained and competent person. Failure to do so may result in location inaccuracies.**

Version	Task	Responsibility	Reason	Date
1	Author	Z. Dredge	First INA branded document version	24/05/2024
2		Z. Dredge	Re-Branding	19/11/2024